



SMR轴装式减速机  
SMR Shaft Mounted Reducer



# SMR 轴装式减速机特性 SMR Reducer Specification

## 1、轴出空心轴

标准轴可选空心轴孔径适合于ISO标准轴径尺寸。

## 2、高精度齿轮

计算机设计斜齿轴、高强度合金钢材料、渗碳淬火、磨齿工艺（部分中间齿轴剃齿工艺），渐开线齿形修形，符合ISO1328-1997标准，每级齿轮传动效率高98%，传动平稳、噪音低。

## 3、高强度箱体

高强度铸铁精度铸造，优良的减振缓冲冲击能力，轴承孔径精密加工，定位销准确定位，保证齿轮的平稳啮合。

## 4、高强度合金钢输入齿轴

高强度合金钢，淬硬处理，轴承档、油封档、输入轴外圆精密磨削，可以承受最大的径向载荷及扭矩。较长输入键槽设计，可以承受较大的冲击，完全符合ISO标准。

## 5、附加箱体支撑角（不包括H、J）

支撑扭力臂螺栓，防止螺栓过紧而拉坏箱体。控制标准扭力臂的安装位置在推荐的范围内。

## 6、逆止器

可选附件，用于减速机不能反转的使用条件下（仅用于13:1及20:1减速机，5:1减速机不推荐使用）。

## 7、轴承及油封

所有轴承均符合ISO标准，油封均匀为骨架式双唇油封。

## 8、橡胶油封盖

使用橡胶油封盖来密封中间齿轴孔，ISO标准孔径尺寸。

## 9、扭力臂附件

用扭力臂来安装调整减速机的空间位置及皮带的松紧。



## 1、Output Hubs

Standard or alternative hubs with metric bores are available to suit international shaft diameters.

## 2、Precision High Quality Gearing

Computer Designed Helical Gear. Strong Alloy Materials for High Load Capacity, Case Carburized for long life, Ground Profile (some intermediate pinions are shaved), Crown tooth Profile, In Conformance with ISO 1328-1997, 98% Efficiency for per Stage, Smooth Quiet Operation with Teeth in Mesh.

## 3、Maximum Capacity Housing Design

Close Grain Cast Iron Construction, Excellent Vibration Dampening & shock Resistance features, Precision Bored and Dowelled to Ensure Accurate In-line Assembly.

## 4、Strong Alloy Steel Shafts

Strong Alloy Steel, Hardened, Ground on journals, Gear Seatings and Extensions, for Maximum Load and Maximum Torsional Loads, Generous Sizes Shaft Keys for Shock Loading and Conform to ISO Standards.

## 5、Additional Case Lugs(Except H and J Gear Case)

Eliminates the Need for Critical Tightening of Torque arm Bolts, Controls Position of Standard Torque Arm Mounting within Recommended limits.

## 6、BackStops

Alternative Parts, Anti-run Back Device, Are Available on all 13:1 and 20:1 Ratio units and do not recommend for 5:1 Units.

## 7、Bearing and Oil seals

Bearing are Adequately Proportioned and Conform to ISO dimension plan, Readily Available World-wide, Oil seals are Double Lipped Garter Spring Type, Ensuring Effective Oil Sealing.

## 8、Rubberised End Caps

Self Sealing Intermediate Cover Plates, to Standard ISO Housing Dimensions.

## 9、Torque Arm Assembly

For Easy Adjustment of the Belt.

## 减速机选型 Gearbox Selection

樱太轴装机SMR系列是在国外先进的传动设备基础上改进的系列化减速机。轴装式齿轮减速机提供了一个非常方便的减速方法，可以直接固定在设备的驱动轴上，不需要把减速机固定在地基上或其他基础上。这样可以少用一个或两个弹性联轴器以及内部的皮带松紧装置，用扭臂上的螺旋扣可以方便快捷的调整皮带的松紧。

樱太轴装机SMR系列共有八种型号，从B到J，最大功率可达130KW，名义速比5:1、13:1以及20:1。可选择不同的输入皮带轮以达到各种各样的输出转速。

减速机用普通的润滑油进行润滑，也可以使用等效的合成油进行润滑。

Yingtai Shaft Mount Reducer are metric in design throughout and have power ratings to AGMA standard. Shaft Mount Reducers provide a very convenient method of reducing speed, since it is mounted directly on the driven shaft instead of requiring foundations of its own. It eliminates the use of one, and sometimes two, flexible couplings and external belt take-up arrangements, A torque-arm anchors the reducer and provides quick, easy adjustment of the Wedge Belts by means of its turnbuckle.

Yingtai Shaft Mount Reducers are manufactured in eight gear case sizes, nominal gear ratios are 5:1,13:1and 20:1, A very wide choice of final driven speeds can be determined by the use of an appropriate input Wedge Belt Drive.

The units will normally be oil lubricated, but they are equally suitable for long life synthetic lubricants.

## 使用系数Service Factor

选出被驱动机械的减速机使用系数。

Select the service factor application to the drive.

使用系数表Service Factor

被驱动机器类型 Types of Driven Machine	每天工作小时数 Operational Hours Par Day		
	10小时以内 Under 10	10到16小时 Under 16	超过16小时 Over 16
<b>均匀载荷 Uniform</b> 搅拌机和混和机-液体或半液体 Agitators and Mixers-Liquid or Semi-Liquid 离心式鼓风机 Blowers-centrifugal 装瓶机 Botting Machines 输送机和升降机-均匀载荷 Conveyors and Elevators-uniformly loaded 蒸煮器 Cookers 洗涤机(无正反转) Laundry Washing Machines (non-reversing) 动力轴 Line Shafts 离合泵和轮泵 Pumps-centrifugal and gear 拉丝机 Wire Drawing Machines	1.0	1.12	1.25
<b>中等冲击载荷 Moderate Shock</b> 搅拌机和混和机-密度不均匀 Agitators and Mixers-variable density 输送机-非均匀载荷 Conveyors-not uniformly loaded 起重机，行走机构和提升机构 Cranes, travel motion and hosisting 拔管机 Drawbench 进给器-脉动载荷 Feeders-pulsating load 卷扬机 Hoists 水泥窑 Kilns 滚筒洗衣机 Laundry Tumblers 起升机 Lifts 三缸或多缸活塞泵 Piston Pumps-with 3 or more cylinders 制浆机和造纸机 Pulp and paper Making and Calenders 橡胶搅拌机和碾光机 Rubber Mixers and Calenders 旋转型过滤器 Rotary Screens 纺织机械 Textile Machinery	1.25	1.40	1.60
<b>强冲击载荷 Heavy Shock</b> 压砖机 Brick Presses 煤砖机 Briquetting Machines 往复式或抖动式输送机 Conveyors-reciprocating and shaker 破碎机 Crushers 往复式给料机 Feeders-reciprocating 锤式破碎机 Hammer Mills 单缸或双缸活塞泵 Piston pumps-1 or 2 cylinders 橡胶割碎机 Rubber Masticators 振动机 Vibrating Machines	1.6	1.6	2.0

# 减速机选型 Gearbox Selection

## 设计功率及输出转速 Design power and output speed

确定减速机的输出转速，即被驱动机器的需求转速。用被驱动机器的需用功率乘以在第一步中选择的使用系数（若需用功率不知道，则可以乘以输入电机的功率）。

注意：减速机在启动或运转时可以瞬时承受两倍的额定扭矩或功率。

Determine the output speed of the gear units, multiply the absorbed power (or Motor power if absorbed power nit known) by the service factor chosen in step 1.

Note: Gear units are momentarily capable of transmitting twice (2X) the rated capacity on start or during operation.

## 选择减速机型号 Unit selection

根据减速机的输出转速及第二步中计算出的功率在第6页和第7页的额定功率表中选出需求的减速机。

选择单级减速或双级减速是根据被驱动机器的需求转速决定的，减速机的额定输出转速即功率表（第6页和第7页）和皮带驱动表（第12页到第15页）中的输出转速。表中没有的转速，请咨询樱太。

注意：当使用5:1减速机时，逆止器不推荐使用。

According to the output speed and design power value form step 2 refer to the power rating tables on page 6 to 7 and select the correct size unit.

The choice of single or double reduction gearbox will be determined by the output speed required . The normal operating speeds for each of the gearboxes may be observed in the power rating (page 6 to 7 ) and belt drive tables (page 12 to 15 ). For other speeds please consult YINGTAI.

Note: When use 5:1 Gear Units, the Back stop do not recommended.

## 驱动皮带选择 Belt drive selection

### 1440转交流电机驱动皮带选择 selection of associated belt drive for 1440 rpm electric motors

#### 1、输出转速

参考皮带选择表（第12页到第15页），在选出的减速机型号及速比下，找到等于或最接近的输出转速，推荐的速比在第一栏中。

#### 2、皮带轮直径

根据输出转速选择对应的电机皮带轮和减速机皮带轮的节圆直径，以及轮槽形式和合适的皮带根数。

注意：很多情况下，为了传递合适动力的目的，推荐用一根皮带；若客户倾向于用多根皮带时，请咨询樱太。

#### 3、中心距

皮带的长度和中心距可以在相应的手册中查出。

注意：12到15页已经给出了大部分最经济的转速需求。若需求比较特殊的转速，请咨询樱太技术中心。当减速机工作时，扭力臂应该在张紧状态。若有任何疑问，请咨询樱太。

### 1.Output Speed

Refer to the Drive Selection Tables (page 12 to 15 ) and under the appropri-late gearbox size and ratio read down the column headed 'Output Speed' until an Output Speed equal or near to that required is found. The suggested gearbox ratio is given in the first column.

### 2.Pulley Diameters

Read across from the chosen output speed to obtain both driving and drives pulley pitch diameters, groove section and the appropriate number of belts.

Note: in many instances one belt is recommended, being adequate for power transmission purposes; where customer preference is for muti-belt drives consult YINGTAI.

### 3.Center Distance

Belt length and center distance can be found by referring to the appropriate pages of the "Wedge Belt Drives" catalogue.

**Note:** Wedge belt drives shown on pages 12 to 15 have given the most economical total drive package for the speed required. If it is necessary to design a special drive, please consult YINGTAI. Torque arm should preferably be in tension when unit is in operation.

## 减速机选型 Gearbox Selection

### 非1440转交流电机驱动皮带选择 Selection of associated belt for driving speeds other than 1440 rpm

#### 1. 减速机的输入转速

用减速机的输出转速（即被驱动机器的需求转速）乘以减速机的精确速比（参考第9页）来确定减速机的输入转速。

#### 2. 选择 'V' 带

根据手册查出相应的V型带。

#### 1、Gearbox input Shaft Speed

Multiply the gearbox output speed by the EXACT GEAR RATIO ( found in the table on page 9 ) to obtain the gearbox input shaft speed.

#### 2、Selection of 'V' Drive

The correct belt drive can now be selected referring to the 'wedgr Bely Drives' catalogue.

### 选型举例 Example

一均匀负载的升降机，输入转速50转每分，输入功率3.6kw，每天工作24小时，电机为4kw，1440转每分，电机和轴装机之间用皮带联接，中心距约700mm，试选择轴装机，皮带及皮带轮。

#### 减速机选择

##### 1、使用系数

从使用系数表中可得该升降机的服务系数是1.25；

##### 2、设计功率

升降机的输入功率为3.6kw，则设计功率为 $1.25 \times 3.6 = 4.5\text{kw}$ ；

##### 3、选择减速机

用4.5kw做为减速机选型的基础，查功率表（第7页）可以选出E13或E20减速机在输出50转每分钟时传递功率为5.81kw。

#### 选择皮带

##### 1. 输出转速

比较经济的皮带驱动应该选择20:1的速比，参考第13页中输出50转每分钟的配置。

##### 2. 皮带轮直径

参考第13页中输出50转每分钟一行中的主动皮带轮和被动皮带轮的直径及皮带的类型及根数，主动带轮直径100mm，被动带轮直径140mm，2根SPA的 'V' 型皮带。

##### 3. 皮带选择

参考 'V型带' 样本可以选择出SPA1800皮带的中心距可以达到711mm。

A shaft Mounted Speed Reducer is required for a uniformly loaded elevator which absorbs 3.6kW at 50 rpm. The prime mover is a 4kW 1440 rpm direct on line start electric motor. A belt drive is required between the motor and gearbox at approximately 700mm centers running for up to 24 hours/Day.

#### Gear Unit Selection

##### 1、Service factor

From table 1 the service factor is 1.25.

##### 2、Design Power

Using the elevator absorbed power of 3.6kW. Design power= $1.25 \times 3.6 = 4.5\text{kw}$

##### 3、Unit selection

Using 4.5kw as the basis for selection reference to the power rating tables (page 7) indicates that E13 or E20 gear unit will transmit 5.81kw at 50 rpm.

#### Selection of associated belt drive

##### 1、Output speed

A more economic belt drive will be obtained if the 20:1 ratio gearbox is selected, any by reference to page 13 in the gearbox drive tables 50 rpm is obtainable.

##### 2、Pulley diameters

On the line giving the output speed of 50 rpm, read across and note the driving and driven pulley pitch diameters together with the numbers of belts required, which for this case is 100 mm and 140 mm, using 2 SPA wedge belts .

##### 3、Belt selection

By reference to the 'wedge belt drives' can be seen that SPA 1800 belts give 711mm centers.

## 额定功率表 Power Rating

额定功率表 (kw) 5:1(单级减速)

Power rating (kw) table for single reduction 5:1 units

输出转速 Output (rpm)	SMR型号 (SMR size)							
	B5	C5	D5	E5	F5	G5	H5	J5
100	2.68	4.20	6.62	10.29	15.12	25.2	36.2	62.2
110	2.87	4.62	7.08	11.03	16.07	27.6	38.9	67.2
120	3.13	5.04	7.46	11.76	17.01	29.9	41.4	72.5
130	3.36	5.31	7.77	12.34	17.85	31.5	43.4	76.7
140	3.56	5.54	8.11	12.71	18.59	32.6	45.2	79.2
150	3.62	5.78	8.30	13.13	19.22	33.6	47.3	81.9
160	3.73	5.88	8.51	13.55	19.95	34.7	48.3	85.1
170	3.83	5.90	8.72	13.76	20.37	35.1	49.9	88.2
180	3.94	6.09	8.93	14.18	21.00	35.7	51.5	90.3
190	4.04	6.30	9.14	14.49	21.53	36.8	52.5	93.5
200	4.20	6.49	9.45	14.91	22.05	37.8	53.6	96.6
210	4.31	6.53	9.66	15.23	22.47	38.5	54.6	98.7
220	4.41	6.72	9.87	15.75	23.10	39.3	56.2	101.9
230	4.53	6.87	10.06	16.07	23.63	40.0	57.3	104.0
240	4.66	7.04	10.29	16.49	24.26	41.1	58.8	107.1
250	4.78	7.14	10.71	16.80	25.04	42.1	60.4	109.2
260	4.89	7.35	10.92	17.01	25.41	43.1	61.3	111.3
270	5.04	7.46	11.13	18.85	26.25	44.1	63.0	113.4
280	5.20	7.56	11.55	18.38	26.78	45.2	64.1	115.5
290	5.36	7.77	11.76	18.90	27.41	46.2	65.1	116.6
300	5.46	7.98	12.08	19.43	27.83	47.4	66.2	118.7
310	5.62	8.17	12.34	19.95	28.67	48.6	67.7	122.9
320	5.78	8.30	12.60	20.27	29.61	49.4	69.4	123.9
330	5.88	8.51	13.02	20.90	30.35	50.9	70.9	125.0
340	6.09	8.72	13.44	21.11	31.08	52.3	71.6	125.5
350	6.30	8.82	13.76	21.84	31.71	53.3	73.5	126.0
360	6.41	9.03	14.18	22.26	32.60	54.6	74.6	128.1
370	6.62	9.24	14.44	22.79	33.60	55.7	75.6	129.2
380	6.72	9.45	14.70	23.10	34.49	56.7	77.7	130.2
390	6.93	9.56	15.23	23.52	35.07	58.8	79.8	131.3
400	7.14	9.66	15.65	23.57	35.91	59.9	81.9	134.2
输出100转/分时扭矩 Nm(torque at100rpm)	256	401	632	983	1444	2407	3457	5940

注意：当使用5:1减速机时，逆止器不推荐使用。

Note: Backstops do not recommended for 5:1 Units .

## 额定功率表 Power Rating

额定功率表 (kw) 13:1或20:1(双级减速)

Power rating(kw)table for double reduction 13:1 and 20:1 units

输出转速 Output (rpm)	SMR型号 (SMR size)							
	B13/B20	C13/C20	D13/D20	E13/E20	F13/F20	G13/G20	H13/H20	J13/J20
10	0.29	0.49	0.82	1.25	1.97	3.11	4.9	7.8
12	0.36	0.58	0.96	1.48	2.45	3.71	5.9	9.2
14	0.42	0.67	1.11	1.73	2.71	4.30	6.8	10.7
16	0.47	0.77	1.27	1.97	3.09	4.89	7.7	12.1
18	0.53	0.86	1.41	2.20	3.44	5.48	8.7	13.6
20	0.59	0.96	1.58	2.43	3.82	6.08	9.5	15.1
22	0.63	1.04	1.73	2.67	4.18	6.63	10.4	16.4
24	0.69	1.13	1.86	2.89	4.55	7.22	11.3	17.9
26	0.75	1.22	2.02	3.13	4.91	7.79	12.1	19.3
28	0.81	1.32	2.18	3.36	5.27	8.35	13.1	20.6
30	0.86	1.41	2.32	3.58	5.63	8.92	13.9	22.5
32	0.92	1.50	2.47	3.81	4.98	9.49	14.8	23.6
34	0.98	1.60	2.63	4.04	6.34	10.04	15.7	25.1
38	1.10	1.79	2.91	4.48	7.05	11.12	17.4	27.6
40	1.16	1.87	3.07	4.71	7.41	11.87	18.2	29.0
42	1.20	1.96	3.19	4.92	7.75	12.39	19.3	30.1
46	1.30	2.13	3.48	5.37	8.28	13.65	21.1	32.6
50	1.42	2.30	3.78	5.81	9.07	14.60	22.8	35.0
52	1.47	2.37	4.00	6.03	9.14	15.23	23.4	35.6
54	1.52	2.47	4.14	6.23	9.42	15.86	24.4	36.3
58	1.64	2.61	4.43	6.66	10.02	16.80	25.8	38.0
62	1.76	2.77	4.71	7.23	10.61	17.96	27.5	40.2
66	1.86	2.94	5.01	7.68	11.24	19.01	29.7	42.5
70	1.96	3.07	5.13	8.11	11.76	20.16	30.6	44.7
74	2.06	3.18	5.42	8.54	12.39	21.11	32.0	47.0
78	2.15	3.32	5.70	8.97	12.92	22.26	33.6	49.2
80	2.23	3.39	5.81	9.19	13.23	22.47	34.3	50.2
85	2.34	3.58	6.14	9.71	13.97	23.31	36.2	52.8
90	2.48	3.79	6.49	10.24	14.60	24.57	37.9	55.3
95	2.61	4.00	6.81	10.50	15.44	23.83	39.0	58.0
100	2.73	4.19	7.15	11.03	16.17	27.09	40.7	60.5
105	2.85	4.41	7.48	11.55	17.01			
110	2.98	4.62	7.81					
115	3.11							
输出100转/分时扭矩 Nm(Torque at100rpm)	277	468	783	1194	1881	2970	4680	7449

注意: 表格中划线的上方配置适合20:1减速机, 较大的输出转速, 推荐使用13:1或5:1减速机。

Note: The line shows the limit of recommended output speed for reducers with 20:1 ratio. For higher speeds use a 13:1 or 5:1 reducer.

# 减速机尺寸 Dimensions

## 轴装式减速机外形尺寸 Shaft Mount Reducer Dimensions

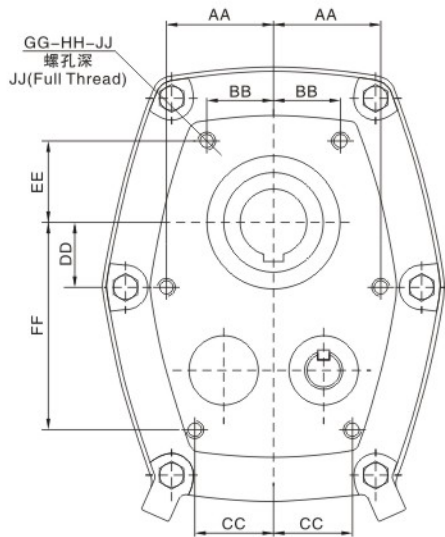

法兰安装 ( Flange mounted )

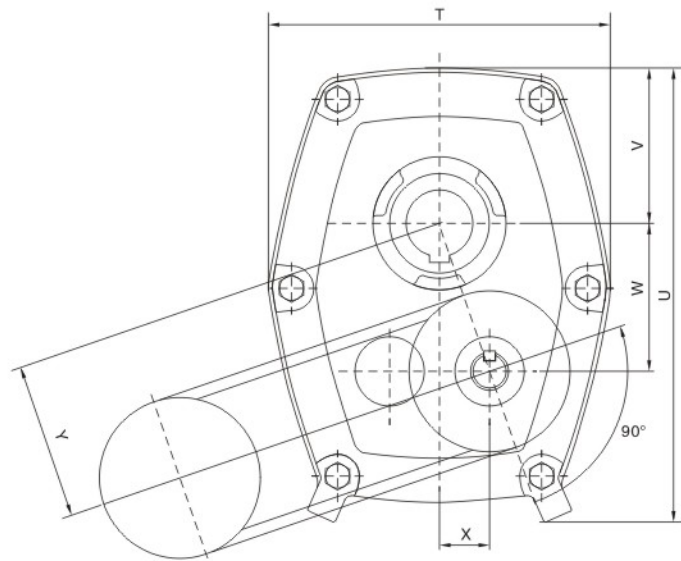

轴装式(SHAFT MOUNTED)

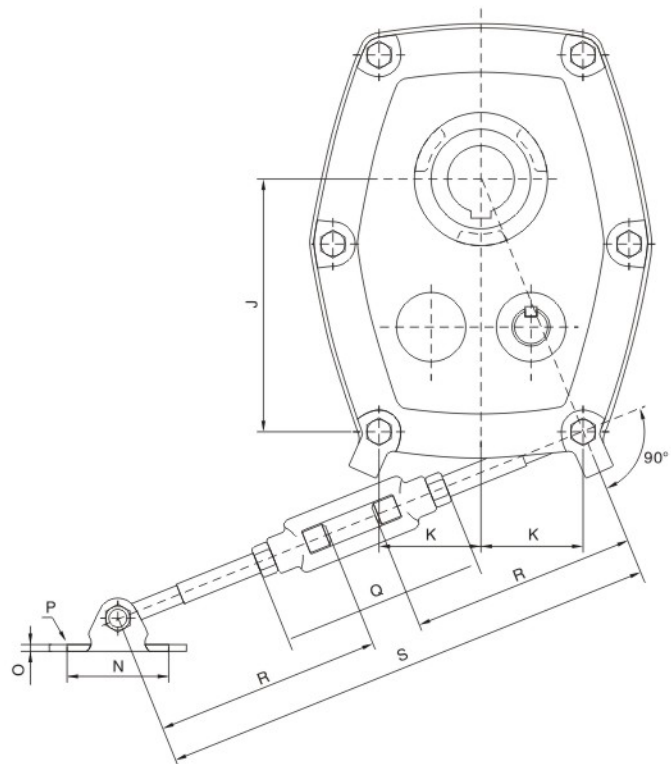
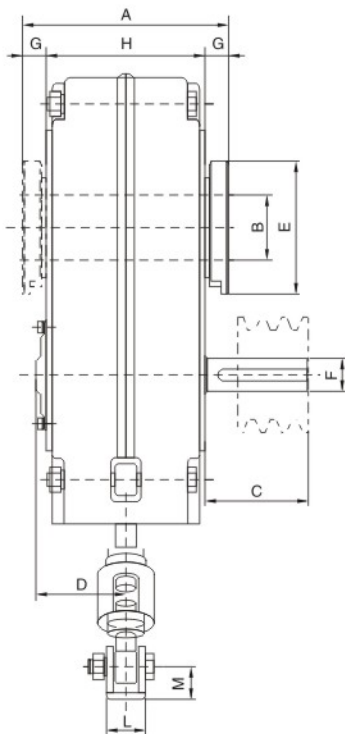



## 减速机尺寸 Dimensions

### 轴装式减速机外形尺寸 Shaft Mount Reducer Dimension

尺寸 Dimension		SMR型号 ( SMR size )							
		B	C	D	E	F	G	H	J
A		134	142	152	170	189	212	242	257
B	标准轴径 standard	30	40	50	55	65	75	85	100
	可选轴径 Alternative	40	50	55	65	75	85	100	120
C		63	72	77	85	90	105	116	135
D		59	65	68	76	87	110	115	119
E		80	90	100	115	130	145	170	200
F		19	22	25	28	32	42	48	55
输入轴键槽(Input Shaft Keyway)		6×3.5×50	6×3.5×59	8×6×63	8×4×70	10×5×70	12×5×90	14×5.5×100	16×6×100
G		15	17	17	20	20	20	26	30
H		104	108	118	130	149	172	190	197
J		131	156	188	222	242	277	330	424
K		55	59	76	90	98	110	88	102
L		24	24	28	28	34	34	70	70
M		20	20	24	24	30	30	50	50
N		65	65	75	75	100	100	120	120
O		5	5	5	5	6	6	18	18
P		10	10	12	12	16	16	16	16
Q		200	200	216	216	216	216	222	222
R		300	300	350	350	375	375	375	375
S	最小 Min	600	600	700	700	750	750	750	750
	最大 Max	750	750	850	850	900	900	900	900
T		186	218	258	278	317	365	434	542
U		241	282	338	386	419	475	550	700
V		81	96	117	129	143	162	195	254
W		75	90	110	125	141	156	189	255
X		25	31	37	43	50	56	62	75
Y		79	95	116	133	150	166	200	266
AA		53	-	-	90	100	115	150	200
BB		34	40	50	57	67	74	64	74
CC		-	44	59	57	76	86	79	-
DD		33	40	48	61	64	74	81	98
EE		41	52	61	62	76	87	122	164
FF		-	132	155	188	197	224	281	330
GG		4	4	4	6	6	6	6	5
HH		M8	M10	M12	M12	M16	M16	M20	M20
JJ		15	15	17	18	19	24	29	32
重量 Weight(kg)	5:1	15	21	30	41	53	82	133	194
	13:1-20:1	16	22	32	46	58	92	144	208
名义 传动比 Normal Ratio	实际传动比 ( Exact gear ratios )								
	5:1	5.05	5.05	5.047	5.047	5.047	5.047	5.047	5.047
	13:1	13.984	13.596	13.589	13.589	13.589	13.589	13.589	13.589
	20:1	20.997	20.466	20.456	20.456	20.456	20.456	20.456	20.456

## 工程技术参数 Engineering / Technical

### 标准输出轴孔 Standard Hub Bores

输出轴孔公差为ISO F7，和其配合的轴径公差推荐用h7。轴键槽尺寸必须符合ISO标准。

比标准输出孔轴径小的输出孔也可以根据客户需要进行加工。尺寸表中可以选输出轴孔径是每种规格最大的输出孔径。

Hubs are bored to F7 limits, A shaft tolerance grade h7 is recommended. Shaft keyways must be to appropriate standard dimensions. Smaller bores are available to customer requirements. The Alternative hub bore is the maximum bore available in each unit size.

### 标准输出轴孔键槽 Standard Hub Keyways

输出轴孔键槽是根据ISO标准加工的，发货时输出轴孔用键不提供。

和输出轴相配的轴上键槽也必须根据ISO标准加工，如下表。

Keyways for the standard output hubs are machined in accordance with ISO standards, Output hub keys are not supplied. Shaft keyways should be machined to suit the standard key size shown below.

轴径 shaft diameter (mm)	20	25	30	32	35	38	40
键 key size(mm)	6×6	8×7	8×7	10×8	10×8	10×18	12×8
轴径 Shaft Diameter(mm)	42	45	50	55	60	65	70
键 Key size (mm)	12×8	14×9	14×9	16×10	18×11	18×11	20×12
轴径 Shaft Diameter(mm)	75	80	85	90	95	100	110
键 Key size (mm)	12×8	14×9	14×9	16×10	18×11	18×11	20×12
轴径 Shaft Diameter(mm)	120	125	-	-	-	-	-
键 Key size (mm)	32×18	32×18					

### 标准输入轴和键 Standard Input Shaft and Keys

输入轴为精磨的ISO h6公差，和其配合的皮带轮或其他轮孔推荐用ISO H7公差。轴键符合ISO标准，参考尺寸表，发货时提供输入轴用平键。

Input shafts are ground to h6 limits, the pulley or other bores' tolerance grade H7 is recommended. Shaft keyways are milled in accordance with ISO standards, see the dimensions in the table, the key is supplied.

## 减速机订购 ordering instructions

### SMR轴装机订购 how to order the SMR gear box

#### SMR轴装机代号 Gearbox Coding

##### 轴装机代号

前三个字母为：**SMR**

第四个字母为减速机型号：B C D E F G H J

第五、第六个字母为减速机速比代号：05 13 20

第七个字母为减速机的安装固定方式：0为轴装式 2为法兰安装

第八个字母为减速机的输出孔径：1为标准输出轴孔径 2为可选输出轴孔径

##### Gearbox coding

First three letters: **SMR**

Fourth letter, unit size: B C D E F G H J

Fifth and sixth digits, ratio code: 05 13 20

Seventh digit. indicates assembly: 0 shaft mounted speed reducer 2 flange mount

Eighth digit: indicates output hub bore required: 1 standard metric bore. 2 alternative metric bore

##### 例如

型号为E 名义速比为20:1，轴装式，标准公制输出孔径（55mm）：**SMR-E2001**

若需要安装逆止器，则必须单独订购，还必须指明输出轴的旋转方向。如：SMR-E2001带逆止器，输出轴一侧，输出空心轴为顺时针转动。

##### Example

Size e unit 20:1 nominal gear ratio, shaft mounted with standard metric hub bore (55mm): **SMR-E2001**.

If backstop are required, these should be order separately. and must specify the output hub rotation. E.g.: SMR-E2001 complete with backstop. in the input shaft side, the output hub's rotation is in clockwise.

### 可选特性 optional Extras

#### 逆止器

当减速机需要反向止动时，可以使用逆止器。打开输入轴另一侧的逆止器盖，可以很方便的安装逆止器。

**注意：**当使用5:1减速机时，不推荐使用逆止器。

#### 法兰安装

SMR轴装机也可以直接用螺栓固定在支撑架上。这种法兰安装的形式允许设计者在应用设计时省掉一个轴承或支座，但是，当然也就把轴装机可以自由调节皮带的松紧的特性消除了，参考第8页。

**注意：**标准SMR齿轮箱没有钻这些安装孔，若需要这种法兰安装方式，则订购时需特别指明。

#### Backstops

A backstop may be incorporated on applications where it is necessary to prevent reversal of rotation. it is quickly installed within the reducer, by simply removing a cover plate.

**Note:** For ratio 5:1 gear box, backstop do not recommended.

#### Flange mounting

SMR case design is such that the reducer can be bolted direct to supporting framework. this flange mounting use of the reducer may permit designers to omit a bearing or pillow block, but it does. of course. eliminate the easy belt adjustment feature characteristic of shaft mount. see page 8.

**Note:** Standard SMR gearbox do not drill mount screws. when customer need these kinds mount, please specify in the order.

# 皮带驱动 Belt Drives

## 1440rpm 电机 1440 rpm Motors

减速机 Unit	名义输出转速 Moninet Output rpm	皮带轮速比 Puley Ratio	皮带轮名义直径 Puley Pitch Diameters (mm)		皮带根数 及类型 Number of Belts
			Motor	Gearbox	
B20	10	6.67	75	500	1SPZ
	12	5.63	71	400	1SPZ
	14	5.00	63	315	1SPZ
	16	4.20	75	315	1SPZ
	18	3.73	75	280	1SPZ
	20	3.50	90	315	1SPZ
	22	3.13	80	250	1SPZ
	24	2.82	71	200	1SPZ
	26	2.63	95	250	1SPA
	27	2.54	63	160	1SPZ
	30	2.25	71	160	1SPZ
	32	2.13	75	160	1SPZ
	34	2.00	80	160	1SPZ
	36	1.88	80	150	1SPZ
	38	1.80	100	180	1SPZ
	39	1.76	71	125	1SPZ
	41	1.67	75	125	1SPZ
	44	1.56	90	140	1SPZ
	46	1.49	75	112	1SPZ
	49	1.41	71	100	1SPZ
	52	1.33	75	100	1SPZ
	55	1.24	90	112	1SPZ
	57	1.20	75	90	1SPZ
	60	1.14	140	160	1SPZ
64	1.07	140	150	1SPZ	
B13	66	1.56	90	140	1SPZ
	69	1.50	100	150	1SPZ
	70	1.47	85	125	1SPA
	72	1.43	140	200	1SPZ
	74	1.39	90	125	1SPZ
	76	1.36	118	160	1SPA
	77	1.34	112	150	1SPZ
	78	1.32	95	125	1SPA
	80	1.29	140	180	1SPZ
	83	1.24	90	112	1SPZ
	85	1.21	132	160	1SPA
	87	1.18	95	112	1SPA
	90	1.14	140	160	1SPZ
	92	1.12	125	140	1SPZ
	97	1.06	132	140	1SPZ
	103	1.00	112	112	1SPZ
	108	0.95	118	112	1SPA
	110	0.94	106	100	1SPA
114	0.90	125	112	1SPA	
B05	119	2.40	75	180	2SPZ
	127	2.24	125	280	2SPZ
	128	2.23	112	250	2SPZ
	135	2.11	95	200	1SPA
	143	2.00	80	160	2SPZ
	145	1.97	71	140	3SPZ
	151	1.89	95	180	1SPA
	160	1.78	90	160	2SPZ
	163	1.75	80	140	2SPZ
	171	1.67	90	150	2SPA
	180	1.58	95	150	2SPA
	183	1.56	90	140	2SPZ
	186	1.53	118	180	1SPA
	194	1.47	95	140	2SPA
	199	1.43	140	200	1SPZ
	210	1.36	118	160	1SPA
	221	1.29	140	180	1SPZ
	228	1.25	112	140	2SPZ
	238	1.20	125	150	1SPA
	250	1.14	132	150	1SPA
	257	1.11	180	200	1SPA
	269	1.06	132	140	1SPA
	285	1.00	160	160	1SPA
	300	0.95	100	95	2SPA
	307	0.93	150	140	1SPA
	320	0.89	140	125	2SPZ
	324	0.88	160	140	1SPA
	344	0.83	180	150	1SPA
	356	0.80	140	112	2SPZ
	366	0.78	180	140	1SPA
	380	0.75	200	150	1SPA
	391	0.73	180	132	1SPA
407	0.70	200	140	1SPA	

减速机 Unit	名义输出转速 Moninet Output rpm	皮带轮速比 Puley Ratio	皮带轮名义直径 Puley Pitch Diameters (mm)		皮带根数 及类型 Number of Belts	
			Motor	Gearbox		
C20	10	7.04	71	500	1SPZ	
	12	5.63	71	400	1SPZ	
	13	5.33	75	400	1SPZ	
	15	4.73	75	355	1SPZ	
	16	4.44	71	315	1SPZ	
	18	3.94	80	315	1SPZ	
	20	3.50	90	315	1SPZ	
	22	3.13	80	250	1SPZ	
	23	3.11	90	280	1SPZ	
	25	2.78	90	250	1SPZ	
	29	2.40	75	180	1SPZ	
	33	2.13	75	160	1SPZ	
	35	2.00	80	160	1SPZ	
	37	1.66	85	160	1SPA	
	40	1.75	80	140	2SPZ	
	43	1.65	85	140	1SPZ	
	45	1.56	90	140	1SPZ	
	47	1.5	100	150	1SPA	
	51	1.39	90	125	1SPA	
	53	1.33	75	100	2SPZ	
	55	1.27	71	90	2SPZ	
	59	1.19	80	95	1SPA	
	63	1.12	85	95	1SPA	
	66	1.07	140	150	2SPZ	
C13	68	1.56	80	125	1SPA	
	70	1.52	132	200	1SPZ	
	72	1.47	95	140	1SPA	
	74	1.43	140	200	1SPZ	
	78	1.36	132	180	1SPA	
	80	1.32	106	140	1SPA	
	82	1.29	140	180	1SPZ	
	85	1.24	90	112	2SPZ	
	88	1.21	132	160	1SPA	
	90	1.18	95	112	1SPA	
	93	1.14	140	160	1SPZ	
	95	1.12	118	132	1SPA	
	100	1.06	132	140	1SPA	
	106	1.00	132	132	1SPA	
	111	0.95	100	95	1SPA	
	C05	113	2.52	125	315	1SPA
		119	2.39	132	315	1SPA
		127	2.25	140	315	1SPA
128		2.22	180	400	1SPZ	
136		2.10	150	315	1SPA	
143		2.00	125	250	2SPZ	
145		1.97	160	315	1SPA	
151		1.89	95	180	2SPA	
159		1.79	140	250	1SPA	
163		1.75	180	315	1SPZ	
170		1.68	95	160	2SPA	
177		1.61	112	180	2SPZ	
180		1.58	200	315	1SPZ	
183		1.56	90	140	3SPZ	
189		1.51	106	160	2SPA	
199		1.43	112	160	2SPA	
210		1.36	132	180	2SPA	
221		1.29	140	180	2SPZ	
228		1.25	160	200	1SPA	
242		1.18	95	112	2SPA	
250		1.14	140	160	2SPZ	
257		1.11	180	200	1SPA	
269		1.06	125	132	1SPA	
285		1.00	140	140	2SPZ	
300		0.95	132	125	1SPA	
317		0.90	200	180	1SPA	
320		0.89	132	118	2SPA	
339		0.84	140	118	2SPA	
344		0.83	160	132	2SPA	
356		0.80	140	112	2SPA	
361		0.79	150	118	2SPA	
366		0.78	180	140	2SPZ	
375	0.76	132	100	3SPA		
380	0.75	200	150	2SPA		
385	0.74	160	118	2SPA		
396	0.72	250	180	1SPA		
402	0.71	140	100	3SPZ		

# 皮带驱动 Belt Drives

## 1440rpm 电机 1440 rpm Motors

减速机 Unit	名义输出转速 Moninet Output rpm	皮带轮速比 Puley Ratio	皮带轮名义直径 Puley Pitch Diameters (mm)		皮带根数 及类型 Number of Belts
			Motor	Gearbox	
D20	10	7.04	71	500	1SPZ
	13	5.63	71	400	1SPZ
	14	5.00	63	315	1SPZ
	16	4.44	71	315	1SPZ
	18	3.97	63	250	2SPZ
	20	3.52	71	250	2SPZ
	22	3.13	80	250	1SPZ
	24	2.94	85	250	1SPA
	27	2.63	95	250	1SPA
	28	2.50	100	250	1SPZ
	30	2.35	85	200	1SPA
	32	2.22	90	200	2SPZ
	33	2.11	95	200	1SPA
	37	1.89	95	180	1SPA
	39	1.80	100	180	1SPA
	40	1.75	80	140	2SPZ
	41	1.70	106	180	1SPA
	44	1.61	112	180	1SPA
	47	1.50	100	150	2SPA
	49	1.44	125	180	1SPZ
	50	1.42	106	150	2SPA
	52	1.36	118	160	1SPA
	53	1.32	106	140	2SPA
	56	1.25	112	140	2SPA
	59	1.20	125	150	1SPA
	60	1.18	85	100	2SPA
63	1.12	118	132	2SPA	
63	1.11	90	100	3SPZ	
66	1.07	140	150	1SPA	
D13	67	1.58	200	315	1SPA
	70	1.52	132	200	1SPA
	72	1.47	95	140	2SPA
	74	1.43	140	200	2SPA
	78	1.36	132	180	2SPA
	80	1.32	106	140	2SPA
	82	1.29	140	180	1SPA
	85	1.25	160	200	1SPA
	88	1.21	132	160	2SPA
	90	1.18	95	112	2SPA
	93	1.14	140	160	2SPZ
	95	1.11	180	200	1SPA
	99	1.07	150	160	2SPA
	101	1.05	95	100	2SPA
	106	1.00	125	125	2SPZ
	D05	114	2.5	160	400
119		2.39	132	315	1SPA
127		2.25	140	315	2SPZ
128		2.23	112	250	2SPA
135		2.12	118	250	2SPA
143		2.00	125	250	2SPA
151		1.89	132	250	2SPA
159		1.80	100	180	3SPA
159		1.79	140	250	2SPZ
163		1.75	180	315	1SPA
170		1.68	95	160	3SPA
177		1.61	112	180	2SPA
181		1.58	200	315	1SPA
188		1.52	132	200	2SPA
200		1.43	140	200	2SPA
204		1.40	100	140	4SPZ
210		1.36	132	180	2SPA
221		1.29	140	180	2SPA
228		1.25	160	200	2SPA
238		1.20	150	180	2SPA
250		1.14	140	160	2SPA
267		1.07	150	160	2SPA
285		1.00	140	140	2SPA
300		0.95	132	125	3SPA
317		0.90	200	180	2SPA
324		0.88	160	140	3SPZ
344	0.83	180	150	2SPA	
357	0.80	200	160	2SPA	
366	0.78	180	140	2SPA	
380	0.75	200	150	2SPA	
391	0.73	180	132	3SPA	
396	0.72	250	180	2SPA	

减速机 Unit	名义输出转速 Moninet Output rpm	皮带轮速比 Puley Ratio	皮带轮名义直径 Puley Pitch Diameters (mm)		皮带根数 及类型 Number of Belts
			Motor	Gearbox	
E20	10	7.04	71	500	1SPZ
	13	5.63	71	400	2SPZ
	14	5.00	80	400	1SPZ
	16	4.44	90	400	1SPZ
	18	4.00	100	400	1SPZ
	20	3.50	90	315	2SPZ
	22	3.15	100	315	1SPZ
	25	2.82	71	200	2SPZ
	26	2.67	75	200	2SPZ
	28	2.50	100	250	2SPZ
	29	2.40	75	180	3SPZ
	31	2.25	80	180	3SPZ
	33	2.11	71	150	3SPZ
	35	2.00	80	160	3SPZ
	37	1.88	85	160	2SPA
	40	1.75	80	140	3SPZ
	42	1.68	95	160	1SPA
	44	1.60	125	200	2SPZ
	46	1.52	132	200	1SPA
	49	1.44	125	180	2SPZ
	50	1.40	100	140	2SPA
	52	1.36	132	180	2SPA
	55	1.29	140	180	2SPA
	56	1.25	100	125	3SPZ
	59	1.20	150	180	1SPA
	60	1.18	106	125	2SPA
62	1.14	140	160	2SPZ	
63	1.11	90	100	4SPZ	
66	1.06	118	125	2SPA	
E13	70	1.52	132	200	2SPZ
	74	1.44	125	180	2SPA
	76	1.39	180	250	1SPA
	78	1.36	118	160	2SPA
	80	1.32	100	132	3SPA
	82	1.29	140	180	2SPA
	85	1.24	90	112	5SPZ
	88	1.21	132	160	2SPA
	90	1.18	95	112	4SPA
	93	1.14	140	160	2SPA
	95	1.12	125	140	3SPZ
100	1.06	132	140	2SPA	
106	1.00	125	125	3SPZ	
E05	107	2.67	150	400	2SPA
	114	2.50	160	400	2SPA
	119	2.39	132	315	2SPA
	127	2.25	140	315	3SPZ
	129	2.22	180	400	2SPA
	136	2.10	150	315	2SPA
	143	2.00	125	250	3SPA
	151	1.89	132	250	3SPA
	154	1.85	170	315	2SPA
	159	1.79	140	250	3SPA
	163	1.75	180	315	2SPA
	168	1.70	132	224	2SPZ
	173	1.65	170	280	2SPB
	178	1.60	125	200	3SPA
	188	1.52	132	200	3SPA
	200	1.43	140	200	3SPA
	210	1.36	132	180	3SPA
	221	1.29	140	180	3SPA
	228	1.25	200	250	2SPA
	238	1.20	150	180	2SPB
	250	1.14	140	160	3SPA
	257	1.11	180	200	2SPA
	269	1.06	212	224	2SPB
	285	1.00	200	200	2SPA
	300	0.95	236	224	2SPB
	304	0.94	160	150	3SPA
317	0.90	250	224	2SPB	
324	0.88	160	140	2SPA	
344	0.83	180	150	3SPA	
357	0.80	250	200	2SPA	
375	0.76	236	180	2SPB	
380	0.75	200	150	3SPA	
391	0.73	180	132	4SPA	
402	0.71	280	200	2SPB	

# 皮带驱动 Belt Drives

1440rpm 电机 1440 rpm Motors

减速机 Unit	名义输出转速 Moninet Output rpm	皮带轮速比 Puley Ratio	皮带轮名义直径 Puley Pitch Diameters (mm)		皮带根数 及类型 Number of Belts
			Motor	Gearbox	
F20	10	7.04	71	500	2SPZ
	13	5.63	71	400	2SPZ
	14	5.00	100	500	1SPA
	17	4.20	75	315	2SPZ
	18	3.94	80	315	2SPZ
	19	3.77	106	400	1SPA
	20	3.57	112	400	1SPA
	22	3.20	125	400	1SPA
	25	2.86	140	400	1SPA
	26	2.67	118	315	2SPZ
	28	2.50	160	400	1SPZ
	30	2.35	85	200	2SPA
	33	2.12	85	180	2SPA
	35	2.00	125	250	2SPZ
	37	1.89	95	180	2SPA
	40	1.75	180	315	1SPA
	42	1.68	95	160	3SPA
	44	1.60	125	200	2SPA
	45	1.58	200	315	1SPA
	49	1.44	125	180	2SPA
	50	1.40	100	140	3SPA
	52	1.36	118	160	2SPA
	55	1.29	140	180	2SPZ
	56	1.25	100	125	4SPZ
	59	1.20	125	150	3SPA
	60	1.18	106	125	3SPA
62	1.14	132	150	2SPA	
63	1.11	106	118	3SPA	
66	1.07	150	160	2SPA	
F13	67	1.58	200	315	2SPZ
	70	1.52	132	200	2SPA
	72	1.48	160	236	2SPB
	74	1.43	140	200	2SPB
	76	1.39	180	250	3SPA
	78	1.36	118	160	3SPA
	80	1.33	150	200	2SPA
	82	1.29	140	180	2SPB
	88	1.20	150	180	2SPB
	88	1.21	132	160	2SPA
	93	1.14	132	150	3SPA
	93	1.14	140	160	3SPA
	95	1.12	125	140	4SPA
	100	1.06	132	140	3SPA
	106	1.00	125	125	4SPA
	F05	112	2.54	140	355
114		2.50	200	500	2SPA
119		2.39	132	315	4SPA
127		2.25	140	315	3SPA
137		2.09	170	355	2SPB
142		2.00	200	400	2SPA
151		1.89	212	400	2SPB
154		1.85	170	315	3SPA
159		1.79	224	400	2SPB
163		1.75	180	315	2SPB
171		1.67	212	355	2SPB
181		1.58	224	355	2SPB
183		1.56	180	280	2SPB
190		1.5	236	355	2SPB
200		1.43	140	200	4SPA
210		1.36	132	180	5SPA
215		1.33	160	212	3SPB
221		1.29	140	180	4SPA
228		1.25	224	280	2SPB
240		1.19	236	280	2SPB
250		1.14	140	160	4SPB
257		1.11	180	200	3SPA
269		1.06	212	224	2SPB
285		1.00	200	200	3SPA
300		0.95	236	224	2SPB
317		0.9	250	224	2SPB
340		0.84	280	236	2SPB
357		0.8	250	200	3SPA
375		0.76	236	180	3SPB
380		0.75	315	236	2SPB
396	0.72	236	170	3SPB	
402	0.71	315	224	2SPB	

减速机 Unit	名义输出转速 Moninet Output rpm	皮带轮速比 Puley Ratio	皮带轮名义直径 Puley Pitch Diameters (mm)		皮带根数 及类型 Number of Belts	
			Motor	Gearbox		
G20	10	7.04	71	500	3SPZ	
	12	5.94	106	630	2SPA	
	14	5.04	125	630	1SPA	
	16	4.44	90	400	3SPZ	
	18	4.00	100	400	2SPA	
	20	3.57	112	400	2SPZ	
	22	3.20	125	400	2SPZ	
	25	2.86	140	400	2SPZ	
	26	2.67	118	315	2SPA	
	28	2.50	160	400	2SPZ	
	30	2.35	85	200	3SPA	
	32	2.23	112	250	3SPZ	
	34	2.10	150	315	2SPA	
	37	1.89	132	250	2SPA	
	40	1.75	180	315	2SPZ	
	42	1.67	150	250	2SPA	
	46	1.53	118	180	3SPA	
	51	1.39	180	250	2SPA	
	55	1.28	125	160	4SPA	
	58	1.21	132	160	4SPA	
	62	1.14	132	150	4SPA	
	66	1.07	150	160	3SPA	
	G13	67	1.58	200	315	2SPA
		70	1.52	132	200	4SPA
		72	1.47	170	250	2SPB
		75	1.41	224	315	2SPB
78		1.36	132	180	5SPA	
81		1.31	180	236	3SPB	
82		1.29	140	180	4SPA	
85		1.25	200	250	2SPB	
88		1.21	132	160	5SPA	
90		1.18	180	212	3SPB	
93		1.14	140	160	5SPA	
95		1.11	180	200	3SPA	
100		1.06	236	250	2SPB	
G05		107	2.67	236	630	2SPB
	113	2.52	250	630	2SPB	
	114	2.50	200	500	3SPA	
	121	2.36	212	500	3SPB	
	127	2.25	280	630	2SPA	
	129	2.22	180	400	4SPA	
	136	2.10	150	315	3SPB	
	143	2.00	250	500	2SPB	
	145	1.97	180	355	4SPB	
	151	1.89	212	400	3SPB	
	154	1.85	170	315	3SPB	
	159	1.79	280	500	2SPB	
	169	1.69	236	400	3SPB	
	171	1.67	212	355	3SPB	
	178	1.60	250	400	2SPB	
	181	1.58	200	315	3SPB	
	190	1.50	236	355	3SPB	
	191	1.49	212	315	3SPB	
	200	1.43	280	400	2SPB	
	202	1.41	224	315	3SPB	
	215	1.33	236	315	3SPB	
	225	1.27	315	400	2SPB	
	228	1.25	224	280	3SPB	
	240	1.19	236	280	3SPB	
	252	1.13	315	355	2SPB	
	255	1.12	224	250	3SPB	
	269	1.06	236	250	3SPB	
	285	1.00	315	315	2SPB	
	304	0.94	250	236	3SPB	
	321	0.89	280	250	3SPB	
321	0.89	355	315	2SPB		
340	0.84	280	236	3SPB		
357	0.80	224	180	4SPB		
361	0.79	315	250	3SPB		
375	0.76	236	180	5SPB		
380	0.75	315	236	3SPB		
396	0.72	236	170	5SPB		
402	0.71	315	224	4SPB		

# 皮带驱动 Belt Drives

1440rpm 电机 1440 rpm Motors

减速机 Unit	名义输出转速 Moninet Output rpm	皮带轮速比 Puley Ratio	皮带轮名义直径 Puley Pitch Diameters (mm)		皮带根数 及类型 Number of Belts
			Motor	Gearbox	
H20	10	7.00	90	630	3SPZ
	12	5.88	85	500	2SPA
	14	5.04	125	630	2SPZ
	16	4.44	90	400	4SPZ
	18	4.00	100	400	3SPA
	20	3.57	140	500	2SPA
	22	3.20	125	400	3SPA
	25	2.86	140	400	2SPA
	26	2.67	150	400	2PSA
	29	2.39	132	315	3SPA
	34	2.10	150	315	2SPB
	36	1.97	160	315	2SPB
	38	1.85	170	315	2SPB
	39	1.79	140	250	3SPB
	42	1.67	150	250	3SPA
	45	1.58	200	315	2SPA
	46	1.52	132	200	4SPA
	51	1.39	180	250	3SPB
52	1.31	180	236	3SPB	
60	1.18	200	236	3SPB	
62	1.13	160	180	4SPA	
66	1.06	236	250	2SPB	
H13	67	1.58	200	315	3SPA
	68	1.56	180	280	3SPB
	71	1.50	236	355	2SPB
	72	1.47	170	250	4SPB
	75	1.41	224	315	3SPA
	76	1.39	180	250	4SPA
	80	1.33	236	315	3SPB
	83	1.27	280	355	2SPB
	85	1.24	180	224	4SPB
	89	1.19	236	280	3SPB
	90	1.18	180	212	4SPB
	95	1.12	250	280	3SPA
100	1.06	200	212	3SPB	
H05	102	2.81	224	630	3SPB
	107	2.67	236	630	3SPB
	113	2.52	250	630	3SPA
	121	2.36	212	500	3SPB
	127	2.25	280	630	2SPB
	136	2.10	150	315	4SPB
	143	2.00	315	630	2SPB
	149	1.91	236	450	3SPC
	151	1.89	212	400	4SPB
	159	1.79	224	400	3SPC
	163	1.75	180	315	5SPB
	169	1.69	236	400	3SPB
	173	1.65	170	280	5SPB
	178	1.60	250	400	3SPB
	181	1.58	200	315	3SPA
	190	1.50	236	355	4SPB
	191	1.49	212	315	4SPB
	200	1.43	280	400	3SPB
	215	1.33	236	315	4SPB
	216	1.32	212	280	4SPB
	225	1.27	280	355	4SPB
	228	1.25	224	280	4SPB
	242	1.18	212	250	4SPC
	252	1.13	315	355	3SPB
	257	1.11	212	236	5SPB
	272	1.05	224	236	4SPC
	285	1.00	280	280	3SPC
	300	0.95	236	224	4SPC
	317	0.90	250	224	4SPB
	321	0.89	315	280	3SPB
	336	0.85	265	224	3SPB
	340	0.84	280	236	4SPB
357	0.80	280	224	4SPB	
361	0.79	355	280	3SPB	
375	0.76	236	180	5SPB	
380	0.75	315	236	3SPC	
396	0.72	250	180	6SPB	
402	0.71	315	224	4SPB	

减速机 Unit	名义输出转速 Moninet Output rpm	皮带轮速比 Puley Ratio	皮带轮名义直径 Puley Pitch Diameters (mm)		皮带根数 及类型 Number of Belts
			Motor	Gearbox	
J20	10	7.00	90	630	4SPZ
	12	5.88	85	500	4SPA
	14	5.00	100	500	4SPZ
	16	4.50	140	630	3SPZ
	17	3.94	160	630	2SPA
	20	3.57	140	500	4SPZ
	22	3.20	125	400	4SPZ
	25	2.86	140	400	3SPA
	26	2.67	150	400	3SPA
	29	2.39	132	315	4SPA
	30	2.35	170	400	3SPB
	34	2.10	150	315	4SPA
	37	1.89	212	400	2SPB
	40	1.75	180	315	3SPB
	42	1.67	212	355	2SPC
	47	1.50	236	355	2SPB
	47	1.49	212	315	2SPC
	50	1.41	224	315	3SPB
54	1.31	180	236	3SPB	
60	1.18	200	236	3SPB	
63	1.11	212	236	3SPB	
66	1.06	212	224	3SPC	
J13	67	1.58	200	315	3SPC
	68	1.56	180	280	4SPB
	71	1.49	212	315	3SPC
	72	1.47	170	250	4SPB
	75	1.41	224	315	3SPC
	76	1.39	180	250	5SPB
	80	1.32	170	224	5SPB
	83	1.27	315	400	2SPC
	85	1.25	200	250	3SPC
	89	1.1	236	280	3SPC
	90	1.18	212	250	4SPB
	95	1.12	250	280	3SPC
100	1.06	212	224	4SPC	
J05	107	2.57	236	630	4SPB
	113	2.52	250	630	4SPB
	121	2.36	212	500	5SPB
	128	2.23	224	500	5SPB
	135	2.12	236	500	5SPB
	143	2.00	250	500	4SPC
	149	1.91	236	450	4SPC
	151	1.89	265	500	4SPC
	153	1.87	300	560	3SPC
	159	1.80	250	450	4SPC
	168	1.70	265	450	4SPC
	171	1.67	300	500	3SPC
	177	1.61	280	450	4SPC
	178	1.59	315	500	4SPB
	189	1.51	265	400	3SPC
	191	1.49	212	315	3SPC
	200	1.43	315	450	3SPC
	202	1.41	355	500	4SPB
	213	1.34	265	355	5SPC
	215	1.33	400	530	3SPC
	225	1.27	315	400	3SPC
	230	1.24	450	560	4SPC
	240	1.19	265	315	5SPC
	252	1.13	280	315	5SPC
	255	1.12	236	265	5SPC
	269	1.06	236	250	5SPC
	272	1.05	224	236	5SPC
	285	1.00	355	355	4SPC
	300	0.95	280	265	5SPC
	304	0.94	250	236	5SPC
	307	0.93	150	140	5SPB
	321	0.89	450	400	4SPC
336	0.85	265	224	5SPC	
340	0.84	400	335	3SPC	
357	0.80	280	224	5SPC	
361	0.79	400	315	3SPC	
380	0.75	355	265	5SPC	
402	0.71	500	355	4SPC	

# 安装 Installation

## 齿轮箱安装 Gearbox Installation

正确的安装，润滑和维护是满意使用的前提，因此仔细阅读并严格照使用说明进行操作是非常必要的。皮带安装及扭力臂安装要注意以下方面。

Satisfactory performance depends on proper installation, lubrication and maintenance, therefore it is important that the instructions in the installation and maintenance leaflet, supplied with each gearbox, are followed carefully. Some of the important aspects of belt and torque-arm installation are listed below.

- 1、输入轴上的皮带轮安装时尽可能的靠近减速机，安装减速机到被驱动机时也应该使减速机尽可能的靠近被驱动机，若安装得太远会使减速机的轴承承受较大的径向力，造成轴承的过早损坏（如图1所示）。
- 2、安装电机时，电机带轮和减速机的输入轴带轮中心的连线应该和减速机输出轴与输入轴中心的连线成大约90°关系（参考图2），这样可以用扭力臂拉紧皮带。如果输出轴是逆时针旋转，扭力臂最好被固定在减速机的右边（参考图3）。
- 3、把扭力臂支座安装在一个固定支撑上，以便使用减速机输出轴中心与扭力臂箱体螺栓的连线与扭力臂成大约90°直角关系（参考图4）。确保扭力臂的调节空间以便正确的调节皮带的松紧。

1. Install pulley on gearbox input shaft as close to the reducer possible, and mount reducer on driven shaft as close to bearing as practical (see figure 1). Failure to do this will cause excess loads in the input shaft bearings and output bearings and could cause their premature failure.

2. Install motor and wedge belt drive with the belt pull at approximately 90° to the center line between driven and input shafts (see fig.2). This will permit tensioning of the wedge belt drive with the torque arm which should preferably be in tension. If output hub runs anti-clockwise, torque arm should be positioned the right (see fig.3).

3. Install torque-arm fulcrum on a rigid support so that the torque-arm will be at approximately right angles to the center line through the driven shaft and the torque arm case bolt (see fig.5). Make sure there is sufficient take up in the turnbuckle for belt tension adjustment.

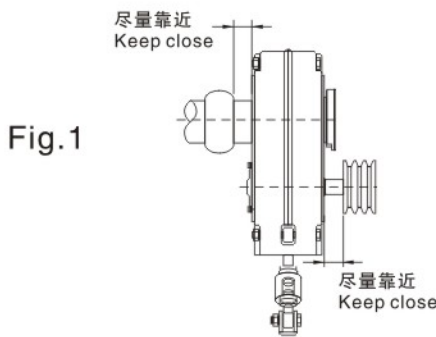

Fig. 1

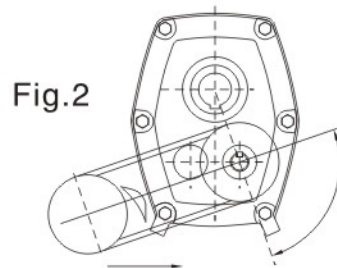

Fig. 2

驱动皮带可以放置于任何方便的位置若扭力臂要调节皮带的松紧，则驱动皮带应该输出轴和输入轴的连接大致垂直。  
Belt drive may be located in any convenient position. If the torque arm is to be used to tighten the belts, the drive should be at about right angle to the line between the input and output shafts.

若需要的话，则驱动皮带也可以放在右边。  
Belt drive may be located to the right if desired.

若输出轴为逆时针旋转，则驱动皮带和扭力臂的安装方位与图示相反。  
If output hub rotates clock-wise, position belt drive and torque arm in opposite direction to that shown in the illustration.

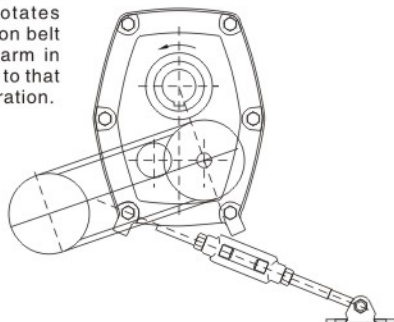
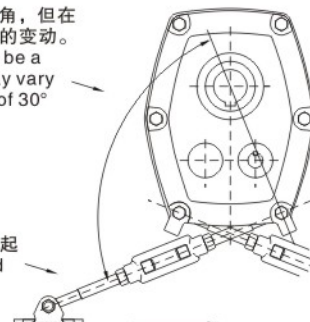

Fig. 3

这个角度大致为直角，但在两侧均可以有30度的变动。  
This angle should be a right angle but may vary up to a maximum of 30° either way.

Fig. 4

扭力臂及皮带拿起  
Torque arm and belt take up.



若需要，扭力臂也可以安装在右侧  
Torque arm may be mounted to the right if desired.



# 润滑和安装方位 Lubrication And Mounting Positions

## 润滑-加油量和推荐润滑油等级

### LUBRICATION-QUANTITIES & RECOMMENDED GRADES

由于轴装式齿轮减速机供货状态为不加润滑油，因此必须在使用前加入合适牌号适量的油，建议用高等级防锈防氧化矿物油。

Shaft mounted reducer is dispatched without oil, it is necessary to fill the proper amount of oil before running, use a high-grade petroleum base rust and oxidation inhibited (R&O) gear oil.

## 加油量 oil quantities(liters)

减速机型号 Unitsize	大致加油量(升) Approximate Capacity-Lofers							
	5.1				13.1 & 20.1			
安装方位 Mounting Position	A	B	C	D	A	B	C	D
B	0.4	0.4	0.4	0.5	0.3	0.4	0.5	0.5
C	0.6	0.6	0.7	0.8	0.5	0.6	0.7	0.7
D	1.0	1.2	1.4	1.5	0.8	1.2	1.5	1.8
E	1.9	1.8	2.0	1.9	1.7	1.8	2.0	1.6
G	2.6	2.5	2.5	2.6	2.8	2.5	2.5	2.5
F	3.3	3.3	4.1	4.6	3.0	3.4	4.3	3.9
H	4.8	5.0	7.1	7.1	4.5	5.0	7.0	6.8
J	9.3	12.0	16.0	16.0	7.5	11.0	14.0	13.0

**安装方位 Mounting Positions**

B: 通气器  
注油孔  
P: 油塞  
L: 油位塞  
D: 排油塞

B: Breather  
Fill Plug  
P: Plug  
L: Oil Level  
D: Drain

注意：输出转速低于15转每分钟时，油位塞必须调整到P油塞处。  
Note: Below 15 rpm output speed, oil level must be adjusted to reach the highest oil level plug (P).

## 矿物油 Mineral Oil

	Environment Temperature	5:1 RATIO GEARBOXES				13:1 and 20:1 RATIO GEARBOXES				
		0-100 rpm	101-200 rpm	201-400 rpm		0-20 rpm	21-50 rpm		51-120 rpm	
		BCDEFGHJ	BCDEFGHJ	BC	DEFGHJ	BCDEFGHJ	BCD	EFGHJ	BCD	EFGHJ
ISO Viscosity Grade	-10~+5	100	100	100	68	150	150	150	100	100
	6~25	460	320	320	220	680	680	460	460	320
	26~40	800	680	680	460	800	800	800	680	460

## 推荐润滑油品牌 Manufacturers and Types

B.P ENERGOL CR-XP	CASTROL ALPHA ZN OR SP	MOBIL MOBILGEAR OIL	SHELL OMALA	TEXACO MEROPE
-------------------------	------------------------------	---------------------------	----------------	------------------

## 合成油 Synthetic oil

DARMEX 9140 NMNND	适用于所有的环境温度和输入转速 SUITABLE FOR ALL AMBIENT TEMPERATURES AND ALL INPUT SPEEDS
----------------------	---

注意：正常情况下一般不推荐使用极压润滑油，除非使用逆止器时推荐使用。

Note: Do not use E. P. mineral oils other than those recommended when using a backstop.

# 皮带安装和减速机应用 Belt Installation And Reducer Application

## 压紧力 tensioning Forces

皮带 Belt	1米跨距16毫米挠度所需压力 Force required to 16mm per meter of span	
	皮带轮直径 Smaity Diameter(mm)	所需压力 Newton(N)
SPZ	56-95	13-20
	100-140	20-25
SPA	80-132	25-35
	140-200	35-45
SPB	112-224	45-65
	236-315	65-85
SPC	224-355	85-115
	375-560	115-150

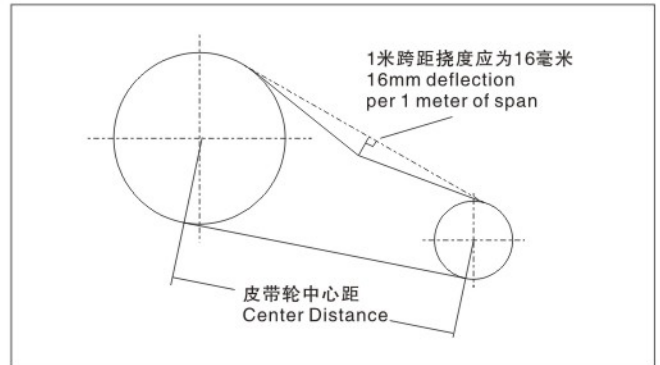

## 皮带紧张调节方法 Method of Belt Tensioning

- 根据皮带轮中心距计算皮带所要挠度值。中心距(米) × 16 = 所需挠度(毫米)。
- 用弹簧称和直尺进行测量其所需压力, 若其值在上述表格中, 则表示皮带松紧合适。否则, 旋转扭力臂的螺旋扣调节。(注意, 施力方向和皮带垂直)
1. Calculate the deflection distance in mm on a basis of 16mm per meter of span. Center distance(m) × 16 = Deflection(mm).
2. Use a spring balance and rule measure the force of the belt, if the value falls within the values given, the drive should be satisfactory. Otherwise, use the Torque arm's turnbuckle adjust the tension of the belt. (Note, the force direction and the belt should be a right angle).

设备类型 Machine Type	典型工业 Typical Industries	应用举例 Application Example
输送机 Conveyors	沙石输送 Sand & Gravel 动物饲养 Animal Feeds 污水处理 Water Treatment 农业 Agriculture 采矿 Quarrying 行李处理 Baggage Handling 散装货物处理 Beggage Handling 港务局 Port Authorities 邮包处理 Post & Parcel 谷物干燥 Grain Dryers	1、筛式进给器主驱动 Head drum drive for screen feeder. 2、倾斜岩石输送带主驱动 Main drive on are inclined basalt conveyor. 3、轮船装载升降机 Ship loading elevator. 4、螺旋输送机主驱动 Main drive to screw conveyer. 5、陆路散货输送带驱动 Overland buck conveyor drives. 6、动物饲料输送带主驱动 Main drive for transporting animal floods. 7、机场行李处理输送带 Airport baggage handling conveyors.
混合机和磨粉机 Mixers & Mills	动物饲养 Animal Feeds 食品工业 Food Industry 农业 Agriculture 石化 Petrochemical 油漆 Paint 过程处理 Process 工业 Industries 搅拌机 Agitator 通风机 Aerators	1、饼干面粉混合机 Biscuit dough mixer. 2、动物饲料磨粉机主驱动 Main drive to animal feed mill. 3、沥青搅拌机主驱动 Main drive for Asphalt agitator. 4、动物饲养工厂用(桨状)搅拌机驱动 Paddle drive on animal feed processing plant.
其他应用 Other Applications	起重机和卷扬机 Cranes & Hoists 绞车 Winches 制革和过程处理 Tanning & Processing 纺织机械 Textile Machinery 洗涤机械 Laundry Machines 机床工具、剪板机等 Machine tools, shears, etc.	1、正反转工业洗涤机 Reversing duty on an industrial washing machine. 2、集装箱起吊设备 Container lifting equipment. 3、气动马达驱动水下绞车系统 Driven by an air motor on an under water winch system. 4、风力涡轮机驱动--用来增速产生电能 Wind turbine drive--used as speed increasing drive to generate electricity.